

Ultrafiltration element

475 UF/MB/TAP

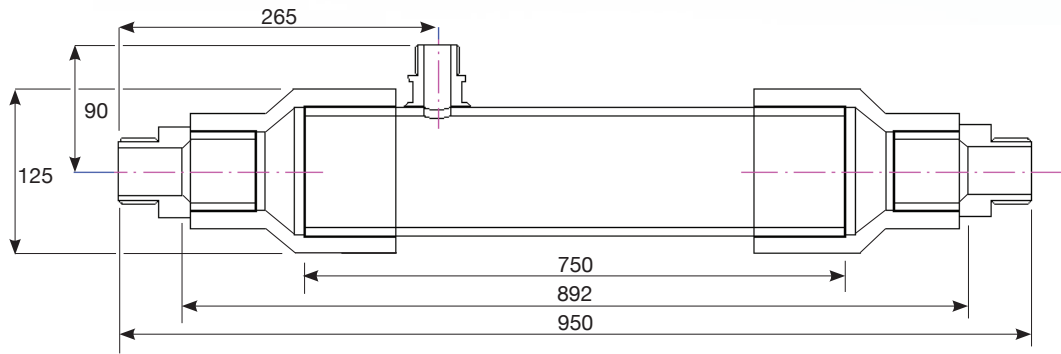

Ultrafiltration element

475 UF/MB/TAP

| Specifications 475 UF/MB/TAP | | SI | | US | |
|--|---|-----------------------|-------------|-----------------|------------|
| Element data | | | | | |
| Material housing | | | PVC | | PVC |
| Material connector | | | PVC | | PVC |
| Housing length | mm | | 750 +/- 2,0 | inch | 30 |
| Element length** | mm | | 892 +/- 3,0 | inch | 35 |
| Element length | mm | | 950 +/- 3,0 | inch | 37 |
| Distance permeate connector-feed connector** | mm | | 236 +/- 2,0 | inch | 9 |
| Distance permeate connector-feed connector | mm | | 265 +/- 2,0 | inch | 10 |
| Distance permeate connector-element center | mm | | 90 +/- 2,0 | inch | 4 |
| Permeate connection male OD | | | 1" | | 1" |
| Feed connection male OD | | | 1" | | 1" |
| Housing OD | mm | | 110 | inch | 4 |
| Element OD | mm | | 125 | inch | 5 |
| Endcaps ID** | mm | | 32 | inch | 1 |
| Weight | kg | | 3,6 | lbs | 8 |
| Membrane Type | | | | | |
| Material | | | PES | | PES |
| Type | | | SevenBore® | | SevenBore® |
| Diameter bores ID | mm | | 0,9 | inch | 0,04 |
| Diameter fiber OD | mm | | 4,0 | inch | 0,16 |
| MWCO | kD | | 100-150 | kD | 100-150 |
| Area | m ² | | 4,25 | ft ² | 46 |
| Typical Process Conditions | | | | | |
| Maximum operating temperature | °C | | 40 | °F | 104 |
| Maximum system pressure | bar | | 10 | psi | 145 |
| Trans membrane pressure | operation | bar | < 1,0 | psi | < 14,5 |
| | maximum | bar | 2,5 | psi | 36 |
| Productivity | clean water at 25° C (77°F) | l/m ² barh | 1300-1600 | gfd/psi | 53-65 |
| | process | l/m ² h | 100 to 350 | gfd | 60 to 210 |
| | backwash/forward flush | l/m ² h | 250 | gfd | 150 |
| Permeate flow at 100 l/m ² h | l/h | | 425 | gpm | 2 |
| pH range during operation | | | 3-10 | | 3-10 |
| Cleaning | | | | | |
| Soaking time during cleaning | | | min 5 | | |
| pH range during cleaning | | | 1-13 | | |
| Disinfecting chemicals | hypochlorite (NaOCl) | | ppm 50-200 | | |
| | hydrogenperoxide (H ₂ O ₂) | | ppm 100-200 | | |

** without screw ends (provided separately)